

# TAZETTA LED (MT5 LED)

## Installation Instructions

LIGHTCORP

### Contents:

- Tazetta LED (MT5 LED) fixture
- (2) Mounting brackets
- (1) Cord clip

### Installation Instructions:

#### BRACKET MOUNT

1. Remove fixture from package and locate the mounting brackets and cord clip. Mounting brackets are attached by sliding through the mounting slots located in each end of the fixture. Slide from rear of the fixture toward the front (Fig. 1).
2. If fixture cord management is necessary, press clip into hole on desired end of fixture and clip cord in place (Fig. 2).
3. Place leading edge of brackets on top of the front edge of the shelf (Fig. 3).
4. Push fixture upward and flex brackets inward to secure in place.
5. Install the lens by angling the front edge into the front lip of the fixture, then press the back edge up and slide back to secure (Fig. 4).
  - For prismatic lens, install with rough side down (out), away from lamp.
  - For batwing lens, install with grooves up (inward), toward the lamp.
6. Plug into 120V, 60Hz grounded outlet.

Fig. 1

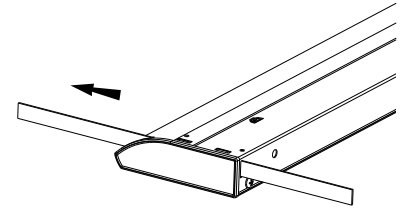

Fig. 2

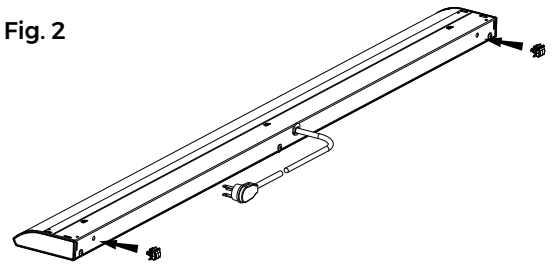

Fig. 3

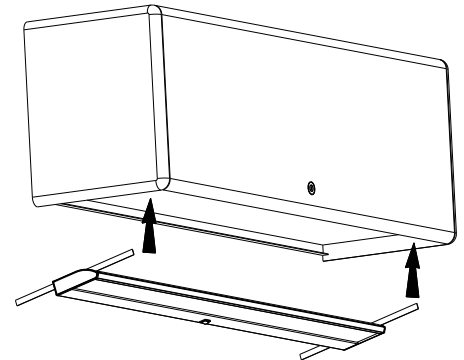

Fig. 4

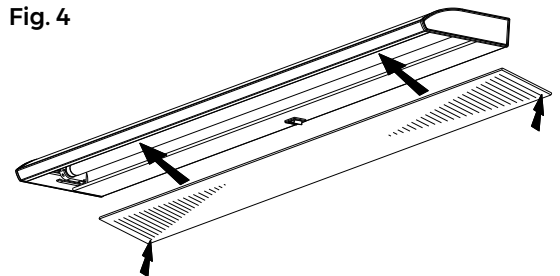
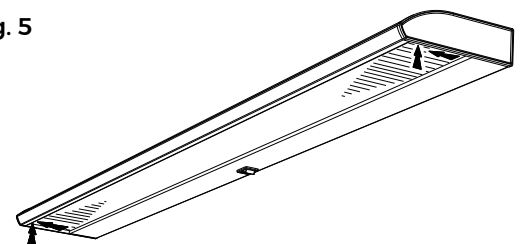

Fig. 5



#### SCREW MOUNT

1. Remove fixture from the package and detach screw kit from cord.
2. Remove the lens and LED lamp. To remove lens, press lens at ends and slide to front of fixture (Fig. 5).
3. Using the table below, determine spacing of screws for the fixture that is being mounted and drill holes in shelf 1/8" diameter by 1/2" deep (Fig. 6).

Nominal length (L)	Mounting spacing (M)
24"	15.93"
36"	27.74"
48"	39.56"

4. With shoulder washer on each screw, drive into pre-drilled holes under shelf. Do not overdrive screws (Figs. 7 & 7a).
5. Cut hole in reflector through each keyhole slot.
6. Hold fixture against shelf until heads of screws pass through large end of keyhole slots.
7. Shift fixture back to engage and replace LED lamp.
8. Install the lens by angling the front edge into the front lip of the fixture, then press the back edge up and slide back to secure (Fig. 4).
  - For prismatic lens, install with rough side down (out), away from lamp.
  - For batwing lens, install with grooves up (inward), toward the lamp.
9. If fixture cord management is necessary, press clip into hole on desired end of fixture and clip cord in place (Fig. 2).
10. Plug into 120V, 60Hz grounded outlet.

## MAGNETIC MOUNT

1. Remove fixture from packaging. The magnet mount hardware is pre-attached.
2. Mount the fixture by placing it under the shelf in the desired location, allowing the magnets to contact the mounting surface (Fig. 8).
3. If fixture cord management is necessary, press clip into hole on desired end of fixture and clip cord in place. (Fig. 2).
4. Plug into 120V, 60Hz grounded outlet.

## Connecting multiple fixtures:

**NOTE:** Maximum of 10 units may be daisy chained together. Only for use with the Tazetta LED (MT5 LED) fixture manufactured by LightCorp. Max 25 watts total connected load.

**CAUTION:** Risk of electric shock or fire. If the cord is not long enough, connect to a power tap with built-in over current protection.

1. Power cord (DCP-fixture) plugs into a 120V, 60Hz power source.
2. Jumper cord (DCJ-fixture) plugs into receptacle of jumper cord on adjacent unit (DCJ-fixture) (Fig. 9).
3. Complete the run by attaching final jumper cord plug (DCJ- fixture) into receptacle of jumper cord on the end unit (DCE-- fixture); this is the only fixture with 1 cord (Fig. 10).

## Installing the cord managers:

Affix to clean, dry surface using firm, direct pressure for 3-5 seconds to achieve a good adhesion to mounting surface.

**NOTE:** No shade is to be attached.

Fig. 6

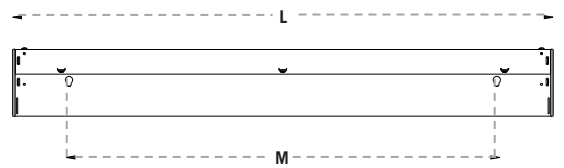

Fig. 7

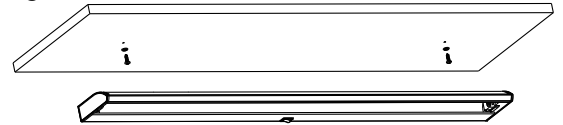

Fig. 7a

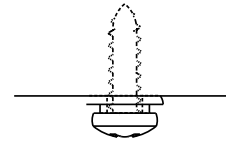

Fig. 8

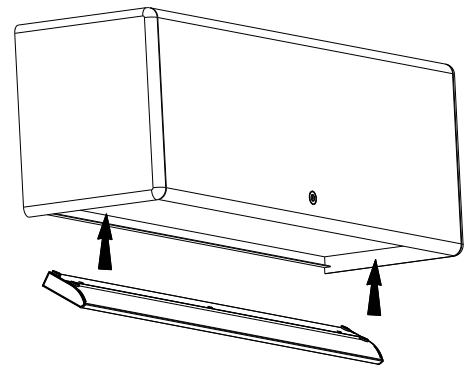

Fig. 9

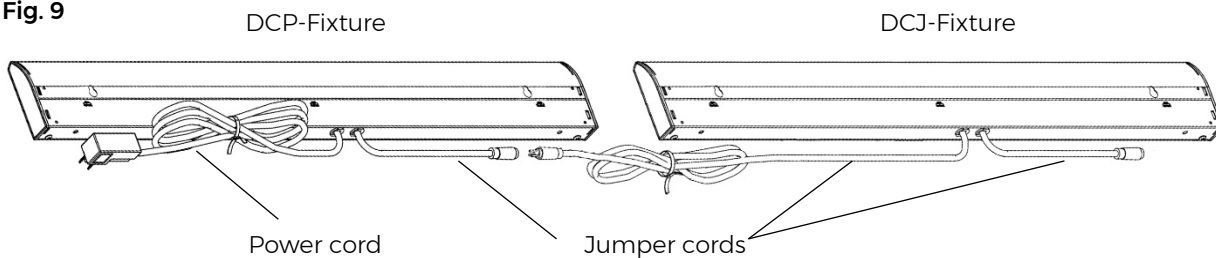
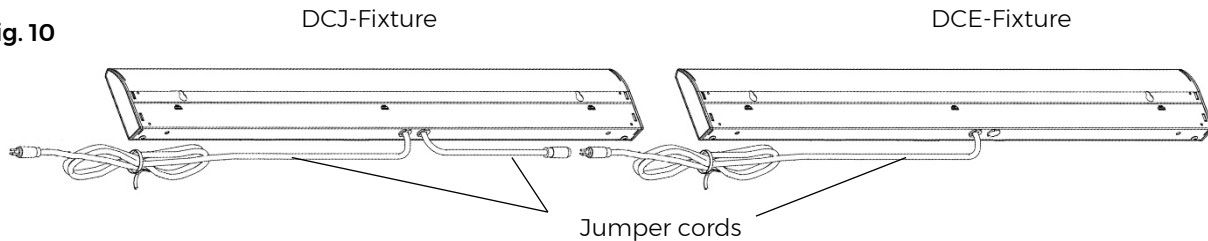

Fig. 10



Note: This equipment has been tested and found to comply with the limits for a Class B digital device, pursuant to Part 15 of the FCC Rules. These limits are designed to provide reasonable protections against harmful interference in a residential installation. This equipment generates, uses, and can radiate radio frequency energy and, if not used in accordance with the instructions, may cause harmful interference to radio communications. However, there is no guarantee that interference will not occur in a particular installation. If this equipment does cause harmful interference to radio or television reception, which can be determined by turning the equipment off and on, the user is encouraged to try to correct the interference by one or more of the following measures: Reorient or relocate the receiving antenna, Increase the separation between the equipment and receiver, Connect the equipment into an output on a circuit different from that to which the receiver is connected, or consult to dealer or an experienced radio/TV technician for help.